

KEY FEATURES

- Temperature Sensor with digital read-out
- 12-bit sigma-delta ADC for digital readout
- Temperature range: -40°C to 125°C
- Accuracy:
 - Step-error: $\pm 0.25^\circ\text{C}$
 - Absolute error: $\pm 1^\circ\text{C}$ (typical), $\pm 5^\circ\text{C}$ (max)
 - Higher accuracy achievable with simple one-step voltage trim
- Support for up to 8 Channels
- Wide Supply Range: 2.7V to 4.2V
- Ultra Low-Power dissipation: 230 μA typical for 8-sensor solution
- Self contained with band-gap reference; no external components needed
- Low Core Low Area
- TSMC 65nm LP process, 2.5V IO transistor, DNWELL

OVERVIEW

The CC0512TS-T65LP is a fully differential low-power temperature sensor combined with a 12-bit sigma delta ADC for digital readout, designed in the 65nm LP process.

It is configurable to support multiple temperature sensors on the same chip, sharing a single digitizer, thus providing the ability to profile the die temperature.

The CC0512TS-T65LP supports a wide power-supply range Fully self-contained with an internal band-gap reference and A/D converter, the temp-sensor is ideal for SoC integration.

DIFFERENTIATION

- In-built accurate 12-bit sigma-delta ADC for digital readout
- Excellent band-gap stability and linearity
- Support for up to 8-channel measurements to profile die-temperature
- Power-down capability with low leakage power
- Wide supply range with support down to 2.7V and up to 4.2V
- Low active power of 2 μA for 32-measurements per second for 8-sensor solution

APPLICATIONS

- On-chip die-temperature measurement
- Hand-held applications
- High-speed server/CPU applications

BLOCK DIAGRAM

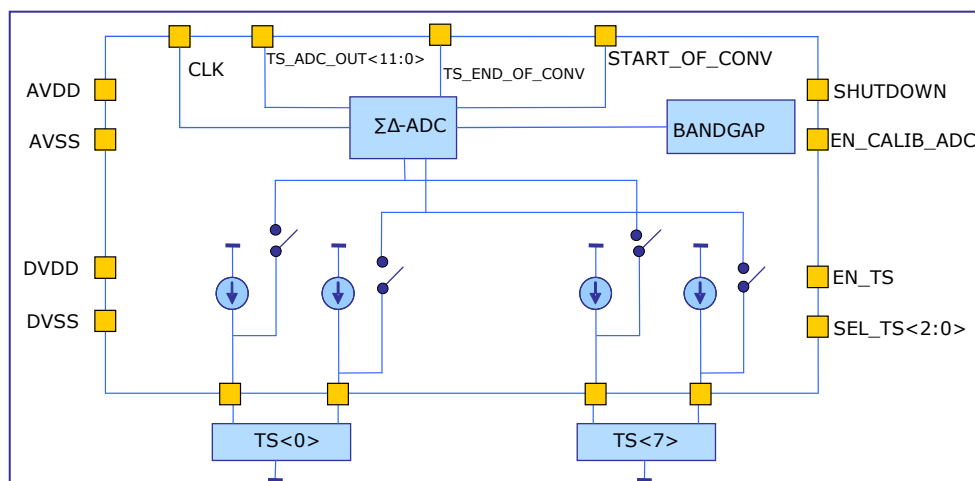

SPECIFICATIONS TABLE

| Parameter | Condition | Value | | | Units |
|---------------------------------------|--|----------------------------|-----|-------|-------|
| | | Min | Nom | Max | |
| Supply Voltage | | 2.7 | | 4.2 | V |
| Temperature range | | -40 | | 125 | C |
| Supply Current (8-sensor solution) | Continuous 2MHz operation | | 230 | | μA |
| | 32 measurements per sec ADC Clock at 1MHz | | | 2.0 | μA |
| | 1 measurement per sec ADC Clock at 1MHz | | | 0.125 | μA |
| Read-out resolution | | 12 | | | Bits |
| ADC Sampling Clock | | | | 2.0 | MHz |
| Number of Channels | | 8 | | | |
| Step-accuracy | | | 0.2 | 0.25 | ±°C |
| Absolute-accuracy | No trim | | 1.0 | 5.0 | ±°C |
| | One-step voltage trim | | | 0.75 | ±°C |
| Process | | TSMC 65LP, 2.5V IO, DNWELL | | | |
| Status | | Silicon Proven | | | |

Note-1: Product specifications are subject to change without notice. No responsibility is assumed for use of information herein.

Note-2: Products specifications such as that described above can typically be altered and customized for specific applications. Contact Cosmic Circuits for more information.

ABOUT COSMIC CIRCUITS

Cosmic Circuits is a provider of differentiated and complex Analog, Mixed-Signal & RF Silicon IP cores. We create and provide IP cores that are best-in-class and thereby make our customers' solutions differentiated and low-cost.

Cosmic Circuits has quickly grown to be a company with the potential to become the destination of choice for world-wide customers for their complex and differentiated Analog, Mixed-Signal & RF Intellectual Property needs.

DIFFERENTIATED IPS

We endeavor to create and provide Analog-IP solutions that are unique in functionality, burn the least amount of power, and take up minimal silicon die-area. 'Best-in-Class' is our Mantra. By using our analog-IP cores, our customers can expect their solution not to be disadvantaged because of analog, and even better, let the analog stand-out as a differentiating factor for the entire solution.

We value our unique blend of deep and broad analog skills and understanding of systems. Our customers can engage with our experts on the type of customization that needs to be done, or the kind of trade-offs to make, and expect the interaction to be a rewarding experience.

DELIVERABLES

We provide the following deliverables to aid quick and reliable integration into the design flow. Please contact us for any additional views.

- ✓ GDSII
- ✓ Netlist (Spice format for LVS)
- ✓ Footprint (LEF format)
- ✓ User documentation
- ✓ Module integration guidelines
- ✓ Datasheet
- ✓ Silicon validation report (where available)
- ✓ Evaluation board (where available)

LICENSING AND CUSTOMIZATION

Our engagements-models includes single-use and multi-use licensing of our IP-cores, Customization of IP-cores, Process porting of the cores to the customers' target process, turn-key development and licensing of customized IP cores and full-chip solutions, as well as supply of Known-Good-Dies (KGD) of full-chip ICs.

SUPPORT

We consider ourselves successful when our customers succeed. We offer active support, both during the chip integration phase and during the product-ramp phase. We offer on-site support when needed. With Cosmic Circuits, our customers can be assured of a reliable partner interested in the success of the end product.

Contact: Cosmic Circuits Pvt. Ltd.,

303, A-Block, AECS Layout, Kundalahalli, Bangalore, India – 560037

Phone: +91-80-41162251 **Fax:** +91-80-41162252 **Email:** ip@cosmiccircuits.com

Url: <http://www.cosmiccircuits.com>